

48V INPUT, 3000W

DC FILTER



PS2307 DC FILTER FEATURES

INPUT:	-38.5 to -72 VDC Input
INPUT CONNECTOR:	Elcon Double Drawer.
PASS THROUGH POWER:	3000 W
OUTPUT CONNECTOR:	Elcon Double Drawer.
PASS THROUGH:	48VDC @ 63A
NOMINAL SIZE:	16" x 4" x 5" (406.4 mm x 101.6 mm x 127 mm)
WEIGHT:	Approx. 12 Lbs.
COOLING:	Internal 90mm 24V fan
OPERATING AMBIENT:	-5 to +55°C
SIGNALS/CONTROLS:	Power OK Signal, Over Temperature Signal, Input - A - OK, Input - B - OK.
INDICATORS:	Input - A - OK LED, Input - B - OK LED, FAULT LED.
PROTECTIONS:	Reverse polarity protection and alarm, Over Current protection, Over Temperature protection.
INRUSH:	Active Inrush Protection.
HOLD-UP TIME:	2 ms min.

MECHANICAL

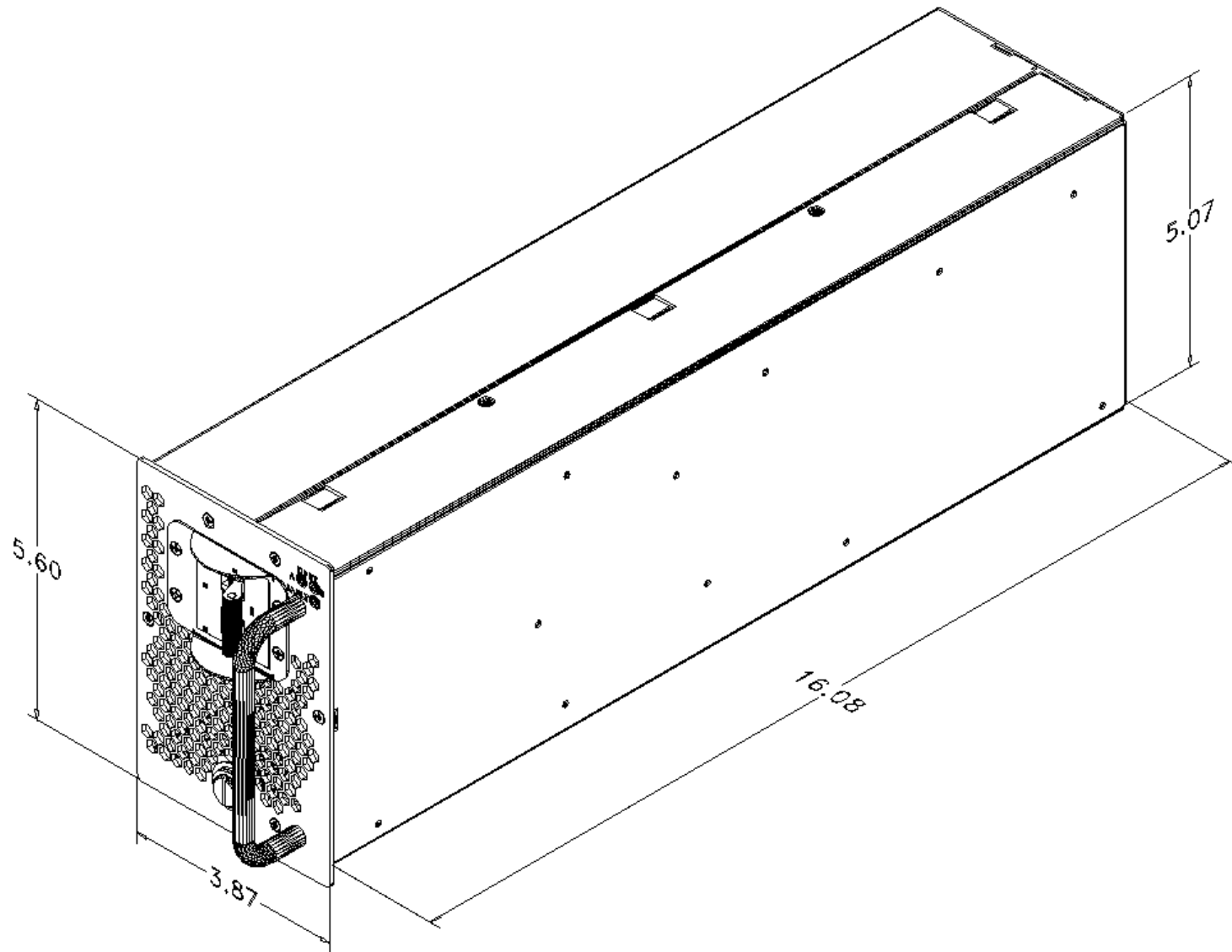



MECHANICAL

